



CURRENT-LIMITED POWER-DISTRIBUTION SWITCHES

FEATURES

- Qualified for Automotive Applications
- 70-mΩ High-Side MOSFET
- 500-mA Continuous Current
- Thermal and Short-Circuit Protection
- Accurate Current Limit:
0.75 A (Min), 1.25 A (Max)
- Operating Range: 2.7 V to 5.5 V
- 0.6-ms Typical Rise Time
- Undervoltage Lockout
- Deglitched Fault Report (\overline{OC})
- No \overline{OC} Glitch During Power Up
- Maximum Standby Supply Current:
1 μ A (Single, Dual) or 2 μ A (Triple, Quad)
- Bidirectional Switch
- Junction Temperature Range: -40°C to 125°C
- ESD Protection Level Per AEC-Q100
Classification
- UL Recognized, File Number E169910

APPLICATIONS

- Heavy Capacitive Loads
- Short-Circuit Protection

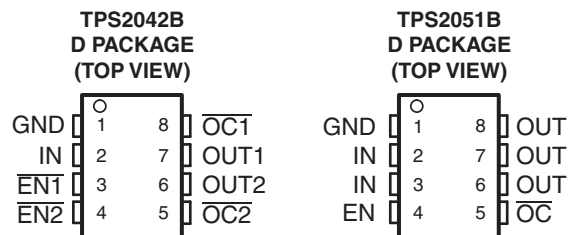

DESCRIPTION

The TPS2042B/TPS2051B power-distribution switches are intended for applications where heavy capacitive loads and short circuits are likely to be encountered. These devices incorporate 70-mΩ N-channel MOSFET power switches for power-distribution systems that require multiple power switches in a single package. Each switch is controlled by a logic enable input. Gate drive is provided by an internal charge pump designed to control the power-switch rise times and fall times to minimize current surges during switching. The charge pump requires no external components and allows operation from supplies as low as 2.7 V.







When the output load exceeds the current-limit threshold or a short is present, the device limits the output current to a safe level by switching into a constant-current mode, pulling the overcurrent (\overline{OCx}) logic output low. When continuous heavy overloads and short circuits increase the power dissipation in the switch, causing the junction temperature to rise, a thermal protection circuit shuts off the switch to prevent damage. Recovery from a thermal shutdown is automatic once the device has cooled sufficiently. Internal circuitry ensures that the switch remains off until valid input voltage is present. This power-distribution switch is designed to set current limit at 1 A (typ).



Please be aware that an important notice concerning availability, standard warranty, and use in critical applications of Texas Instruments semiconductor products and disclaimers thereto appears at the end of this data sheet.

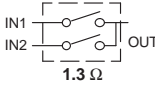

These devices have limited built-in ESD protection. The leads should be shorted together or the device placed in conductive foam during storage or handling to prevent electrostatic damage to the MOS gates.

GENERAL SWITCH CATALOG							
<p>33 mΩ, single</p>  <p>TPS201xA 0.2 A – 2 A TPS202x 0.2 A – 2 A TPS203x 0.2 A – 2 A</p>	<p>80 mΩ, dual</p>  <p>TPS2042B 500 mA TPS2052B 500 mA TPS2046 250 mA TPS2056 250 mA TPS2062 1 A TPS2066 1 A TPS2060 1.5 A TPS2064 1.5 A</p>	<p>80 mΩ, dual</p>  <p>TPS2080 500 mA TPS2081 500 mA TPS2082 500 mA TPS2090 250 mA TPS2091 250 mA TPS2092 250 mA</p>	<p>80 mΩ, triple</p>  <p>TPS2043B 500 mA</p>	<p>80 mΩ, quad</p>  <p>TPS2044B 500 mA TPS2054B 500 mA TPS2048 250 mA TPS2058 250 mA</p>	<p>80 mΩ, quad</p>  <p>TPS2085 500 mA TPS2086 500 mA TPS2087 500 mA TPS2095 250 mA TPS2096 250 mA TPS2097 250 mA</p>	<p>80 mΩ, single</p>  <p>TPS2014 600 mA TPS2015 1 A TPS2041B 500 mA TPS2051B 500 mA TPS2045 250 mA TPS2055 250 mA TPS2061 1 A TPS2065 1 A</p>	<p>260 mΩ</p>  <p>TPS2100/1 IN1 500 mA IN2 10 mA TPS2102/3/4/5 IN1 500 mA IN2 100 mA</p> <p>1.3 Ω</p>

ORDERING INFORMATION⁽¹⁾

T _J	ENABLE	NO. OF SWITCHES	PACKAGE ⁽²⁾		ORDERABLE PART NUMBER	TOP-SIDE MARKING
–40°C to 125°C	Active high	Single	SOIC – D	Reel of 2500	TPS2051BQDRQ1	2051BQ
	Active low	Dual	SOIC – D	Reel of 2500	TPS2042BQDRQ1	2042B

(1) For the most current package and ordering information, see the Package Option Addendum at the end of this document, or see the TI web site at www.ti.com.

(2) Package drawings, thermal data, and symbolization are available at www.ti.com/packaging.

ABSOLUTE MAXIMUM RATINGS⁽¹⁾

over operating free-air temperature range unless otherwise noted

		VALUE	
$V_{I(IN)}$	Input voltage range (IN) ⁽²⁾	–0.3 V to 6 V	
$V_{O(OUT)},$ $V_{O(OUTx)}$	Output voltage range (OUT, OUTx) ⁽²⁾	–0.3 V to 6 V	
$V_{I(ENx)},$ $V_{I(EN)}$	Input voltage range (\overline{ENx} , EN)	–0.3 V to 6 V	
$V_{I(OC)},$ $V_{I(OCx)}$	Voltage range (\overline{OC} , \overline{OCx})	–0.3 V to 6 V	
$I_{O(OUT)},$ $I_{O(OUTx)}$	Continuous output current	Internally limited	
Continuous total power dissipation		See Dissipation Ratings	
T_J	Operating virtual-junction temperature range	–40°C to 125°C	
T_{stg}	Storage temperature range	–65°C to 150°C	
Lead temperature, soldering		1,6 mm (1/16 in) from case for 10 s 260°C	
Electrostatic discharge (ESD) protection	TPS2042B	Human-Body Model (HBM) (H2)	2500 V
		Machine Model (MM) (M0)	50 V
		Charged-Device Model (CDM) (C5)	1500 V
	TPS2051B	Human-Body Model (HBM) (H2)	2000 V
		Machine Model (MM) (M0)	50 V
		Charged-Device Model (CDM) (C5)	1500 V

(1) Stresses beyond those listed under *absolute maximum ratings* may cause permanent damage to the device. These are stress ratings only, and functional operation of the device at these or any other conditions beyond those indicated under *recommended operating conditions* is not implied. Exposure to absolute-maximum-rated conditions for extended periods may affect device reliability.

(2) All voltages are with respect to GND.

DISSIPATING RATINGS

PACKAGE	$T_A \leq 25^\circ\text{C}$ POWER RATING	DERATING FACTOR ABOVE $T_A = 25^\circ\text{C}$	$T_A = 70^\circ\text{C}$ POWER RATING	$T_A = 85^\circ\text{C}$ POWER RATING
D-8	585.82 mW	5.8582 mW/°C	322.20 mW	234.32 mW

RECOMMENDED OPERATING CONDITIONS

		MIN	MAX	UNIT
$V_{I(IN)}$	Input voltage (IN)	2.7	5.5	V
$V_{I(ENx)},$ $V_{I(EN)}$	Input voltage (\overline{ENx} , EN)	0	5.5	V
$I_{O(OUT)},$ $I_{O(OUTx)}$	Continuous output current (OUT, OUTx)	0	500	mA
T_J	Operating virtual-junction temperature	–40	125	°C

ELECTRICAL CHARACTERISTICS

over recommended operating junction temperature range, $V_{I(IN)} = 5.5\text{ V}$, $I_O = 0.5\text{ A}$, $V_{I(ENx)} = 0\text{ V}$ (unless otherwise noted)

PARAMETER		TEST CONDITIONS ⁽¹⁾		MIN	TYP	MAX	UNIT
Power Switch							
$r_{DS(on)}$	Static drain-source on-state resistance, 5-V or 3.3-V operation	$V_{I(IN)} = 5\text{ V}$ or 3.3 V , $I_O = 0.5\text{ A}$	$-40^\circ\text{C} \leq T_J \leq 125^\circ\text{C}$	70	135		m Ω
	Static drain-source on-state resistance, 2.7-V operation ⁽²⁾	$V_{I(IN)} = 2.7\text{ V}$, $I_O = 0.5\text{ A}$	$-40^\circ\text{C} \leq T_J \leq 125^\circ\text{C}$	75	150		
t_r	Rise time, output ⁽²⁾	$V_{I(IN)} = 5.5\text{ V}$	$C_L = 1\text{ }\mu\text{F}$, $R_L = 10\text{ }\Omega$	$T_J = 25^\circ\text{C}$	0.6	1.5	ms
		$V_{I(IN)} = 2.7\text{ V}$			0.4	1	
t_f	Fall time, output ⁽²⁾	$V_{I(IN)} = 5.5\text{ V}$			0.05	0.5	
		$V_{I(IN)} = 2.7\text{ V}$			0.05	0.5	
Enable Input ($\overline{\text{EN}}$, $\overline{\text{ENx}}$)							
V_{IH}	High-level input voltage	$2.7\text{ V} \leq V_{I(IN)} \leq 5.5\text{ V}$		2			V
V_{IL}	Low-level input voltage	$2.7\text{ V} \leq V_{I(IN)} \leq 5.5\text{ V}$				0.8	V
I_I	Input current	$V_{I(ENx)} = 0\text{ V}$ or 5.5 V		-0.5		0.5	μA
t_{on}	Turn-on time ⁽²⁾	$C_L = 100\text{ }\mu\text{F}$, $R_L = 10\text{ }\Omega$				3	ms
t_{off}	Turn-off time ⁽²⁾	$C_L = 100\text{ }\mu\text{F}$, $R_L = 10\text{ }\Omega$				10	ms
Current Limit							
I_{OS}	Short-circuit output current	$V_{I(IN)} = 5\text{ V}$, OUT connected to GND, device enabled into short-circuit	$T_J = 25^\circ\text{C}$	0.75	1	1.25	A
			$-40^\circ\text{C} \leq T_J \leq 125^\circ\text{C}$	0.7	1	1.3	
Supply Current (TPS2051B)							
Supply current, low-level output	No load on OUT, $V_{I(EN)} = 0\text{ V}$	$T_J = 25^\circ\text{C}$	0.5	1		μA	
		$-40^\circ\text{C} \leq T_J \leq 125^\circ\text{C}$	0.5	5			
Supply current, high-level output	No load on OUT, $V_{I(EN)} = 5.5\text{ V}$	$T_J = 25^\circ\text{C}$	43	60		μA	
		$-40^\circ\text{C} \leq T_J \leq 125^\circ\text{C}$	43	70			
Leakage current	OUT connected to ground, $V_{I(EN)} = 0\text{ V}$				1	μA	
Reverse leakage current	$V_{I(OUTx)} = 5.5\text{ V}$, IN = ground ⁽²⁾				0	μA	
Supply Current (TPS2042B)							
Supply current, low-level output	No load on OUT, $V_{I(ENx)} = 5.5\text{ V}$	$T_J = 25^\circ\text{C}$	0.5	1		μA	
		$-40^\circ\text{C} \leq T_J \leq 125^\circ\text{C}$	0.5	5			
Supply current, high-level output	No load on OUT, $V_{I(ENx)} = 0\text{ V}$	$T_J = 25^\circ\text{C}$	50	70		μA	
		$-40^\circ\text{C} \leq T_J \leq 125^\circ\text{C}$	50	90			
Leakage current	OUT connected to ground, $V_{I(ENx)} = 5.5\text{ V}$				1	μA	
Reverse leakage current	$V_{I(OUTx)} = 5.5\text{ V}$, IN = ground ⁽²⁾				0.2	μA	
Undervoltage Lockout							
Low-level input voltage, IN, INx				2		2.5	V
Hysteresis, IN, INx			$T_J = 25^\circ\text{C}$		75		mV
Overcurrent ($\overline{\text{OC}}$, $\overline{\text{OCx}}$)							
Output low voltage, $V_{OL(OCx)}$		$I_{O(OCx)} = 5\text{ mA}$				0.4	V
Off-state current ⁽²⁾		$V_{O(OCx)} = 5\text{ V}$ or 3.3 V				1	μA
$\overline{\text{OC}}$ deglitch ⁽²⁾		$\overline{\text{OCx}}$ assertion or deassertion		4	8	15	ms
Thermal Shutdown⁽³⁾							
Thermal shutdown threshold ⁽²⁾				135			$^\circ\text{C}$
Recovery from thermal shutdown ⁽²⁾				125			$^\circ\text{C}$
Hysteresis ⁽²⁾					10		$^\circ\text{C}$

(1) Pulse-testing techniques maintain junction temperature close to ambient temperature; thermal effects must be taken into account separately.

(2) Specified by design

(3) The thermal shutdown only reacts under overcurrent conditions.

DEVICE INFORMATION

Terminal Functions (TPS2051B)

TERMINAL		I/O	DESCRIPTION
NAME	NO.		
EN	4	I	Enable input, logic high turns on power switch
GND	1		Ground
IN	2, 3	I	Input voltage
\overline{OC}	5	O	Overcurrent open-drain output, active low
OUT	6, 7, 8	O	Power-switch output

Functional Block Diagram (TPS2051B)

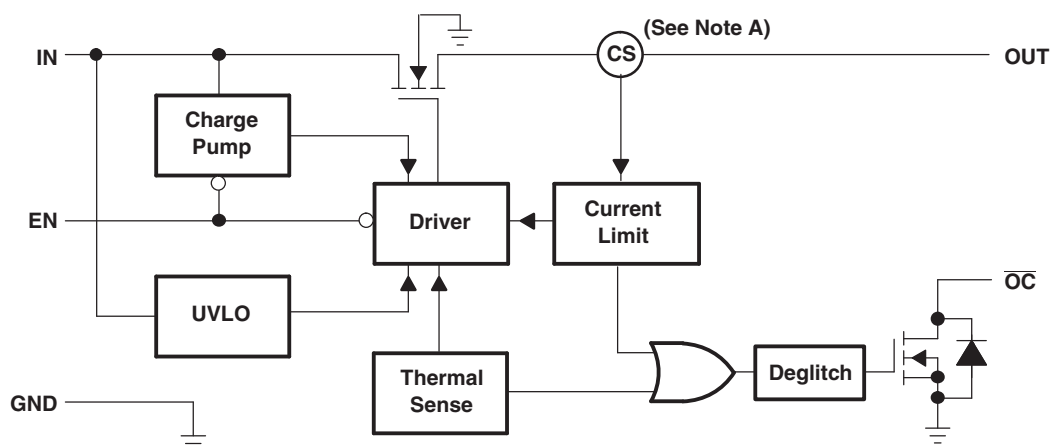

A. CS = Current sense

Terminal Functions (TPS2042B)

TERMINAL		I/O	DESCRIPTION
NAME	NO.		
EN1	3	I	Enable input, logic low turns on power switch IN-OUT1
EN2	4	I	Enable input, logic low turns on power switch IN-OUT2
GND	1		Ground
IN	2	I	Input voltage
OC1	8	O	Overcurrent, open-drain output, active low, IN-OUT1
OC2	5	O	Overcurrent, open-drain output, active low, IN-OUT2
OUT1	7	O	Power-switch output, IN-OUT1
OUT2	6	O	Power-switch output, IN-OUT2

Functional Block Diagram (TPS2042B)

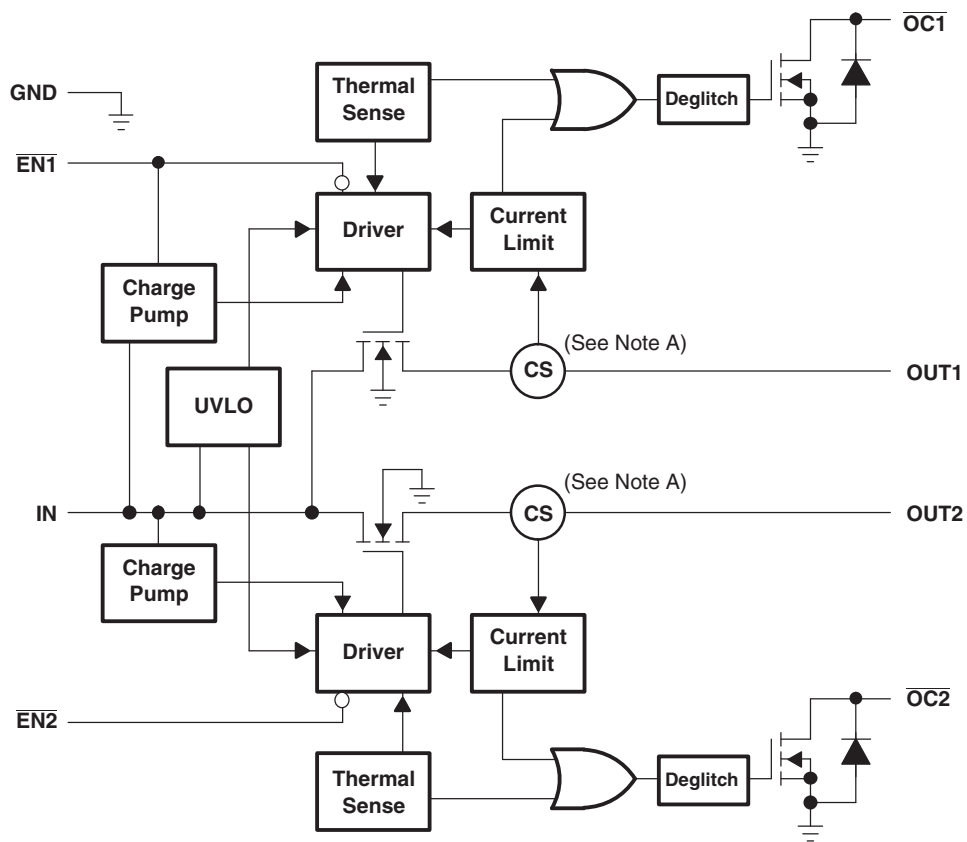

A. CS = Current sense

PARAMETER MEASUREMENT INFORMATION

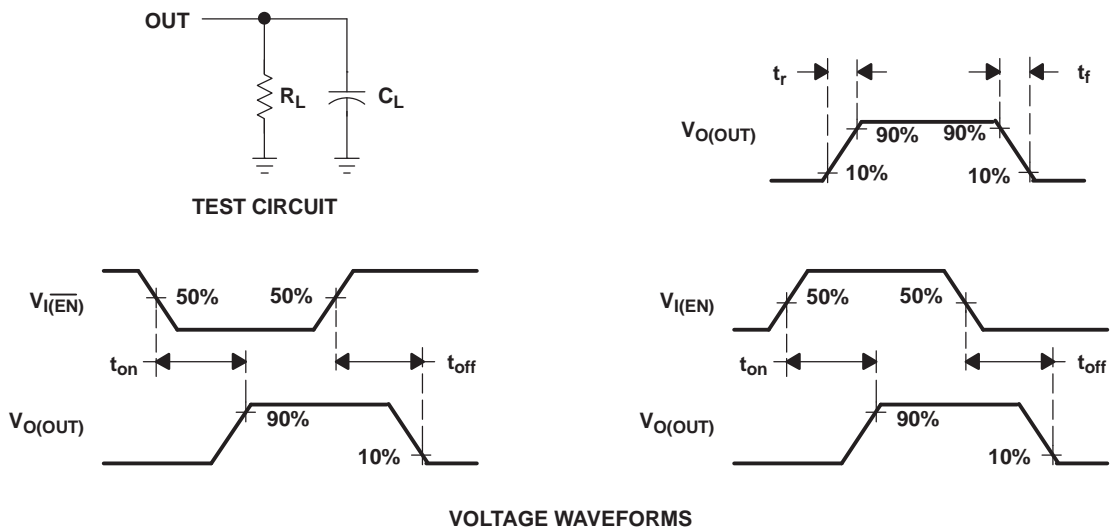

Figure 1. Test Circuit and Voltage Waveforms

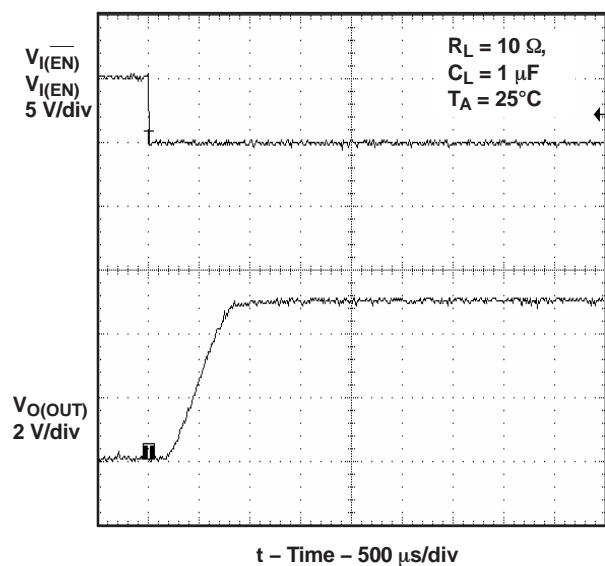

Figure 2. Turn-On Delay and Rise Time With 1- μ F Load

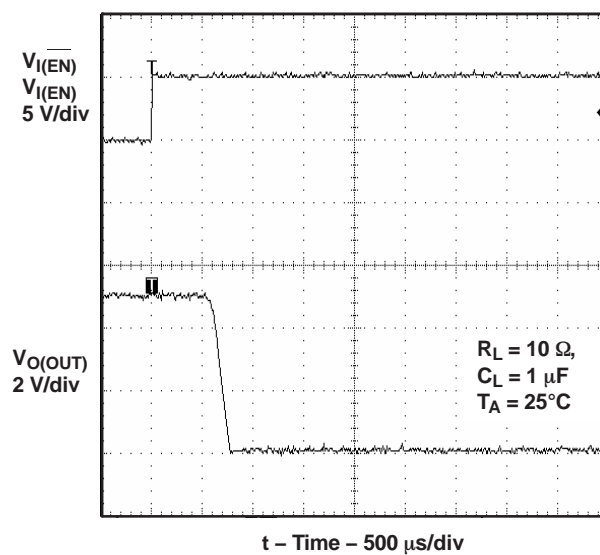

Figure 3. Turn-Off Delay and Fall Time With 1- μ F Load

PARAMETER MEASUREMENT INFORMATION (continued)

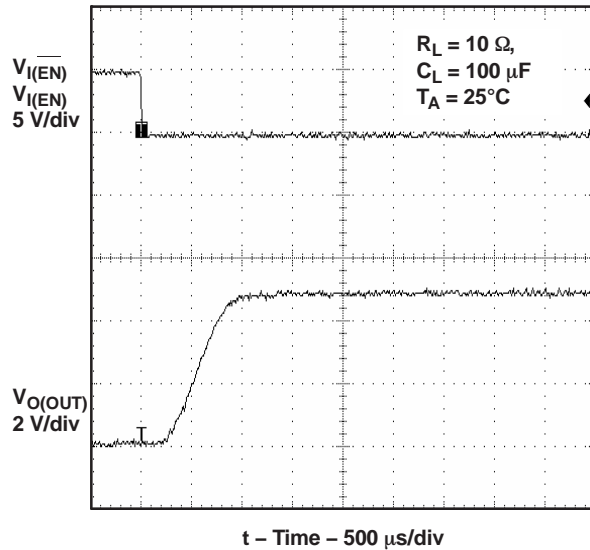

Figure 4. Turn-On Delay and Rise Time With 100-µF Load

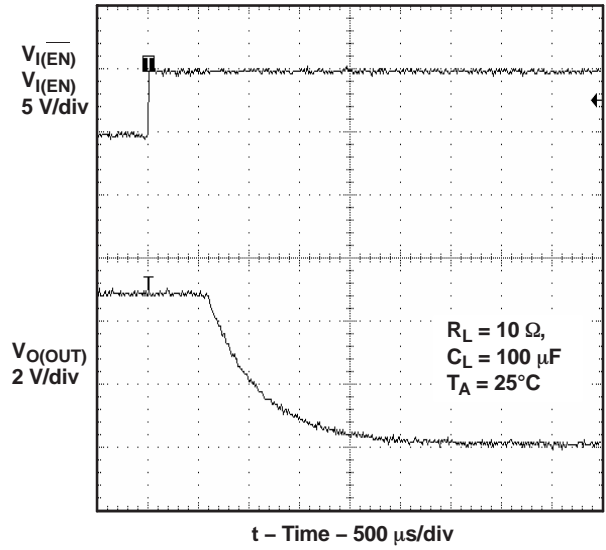

Figure 5. Turn-Off Delay and Fall Time With 100-µF Load

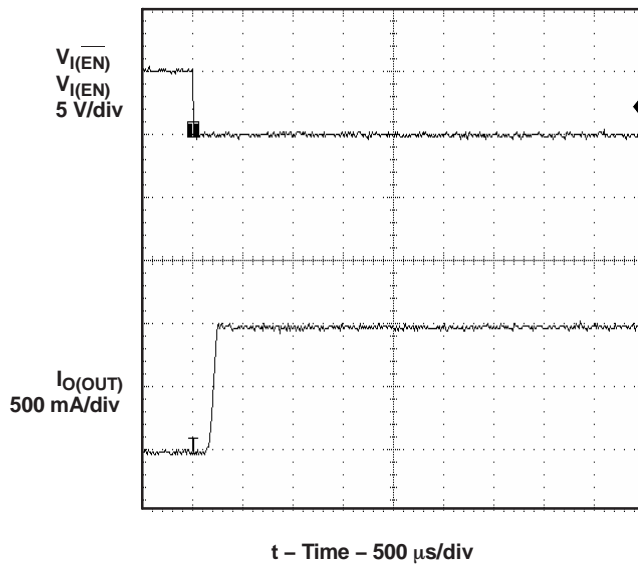

Figure 6. Short-Circuit Current, Device Enabled Into Short

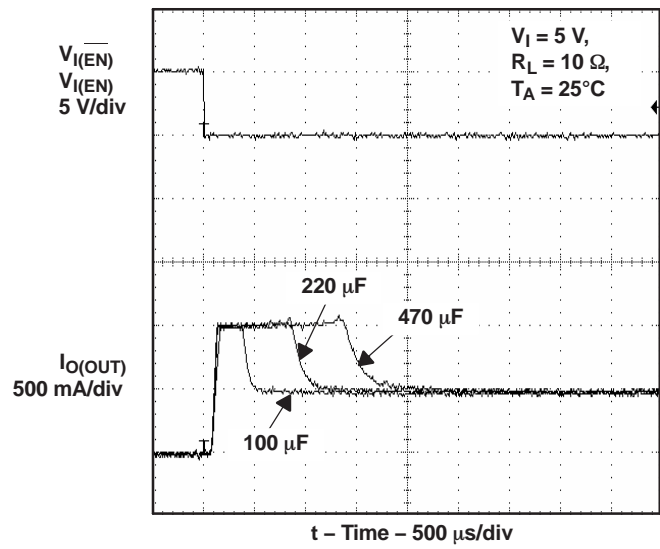

Figure 7. Inrush Current With Different Load Capacitance

PARAMETER MEASUREMENT INFORMATION (continued)

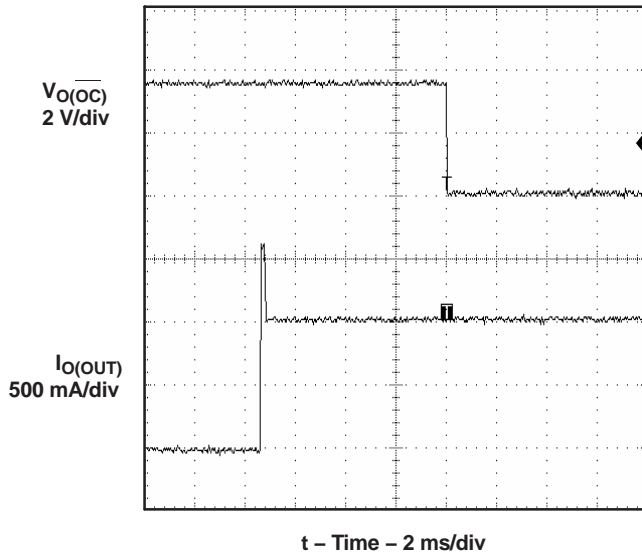

Figure 8. 3- Ω Load Connected to Enabled Device

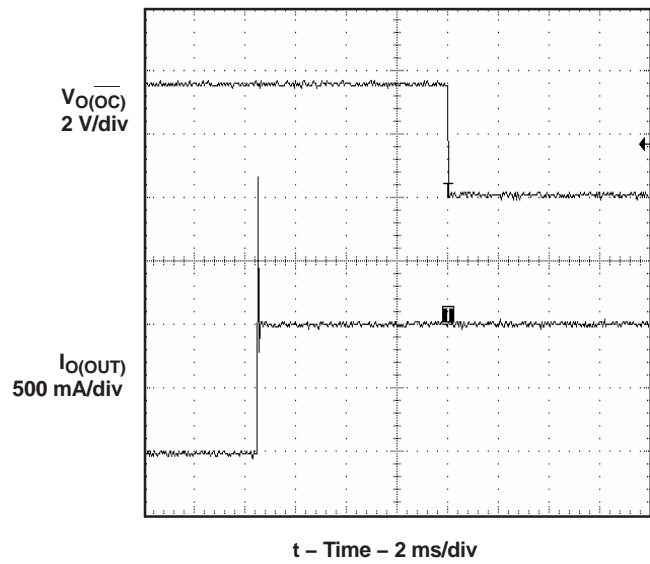

Figure 9. 2- Ω Load Connected to Enabled Device

TYPICAL CHARACTERISTICS

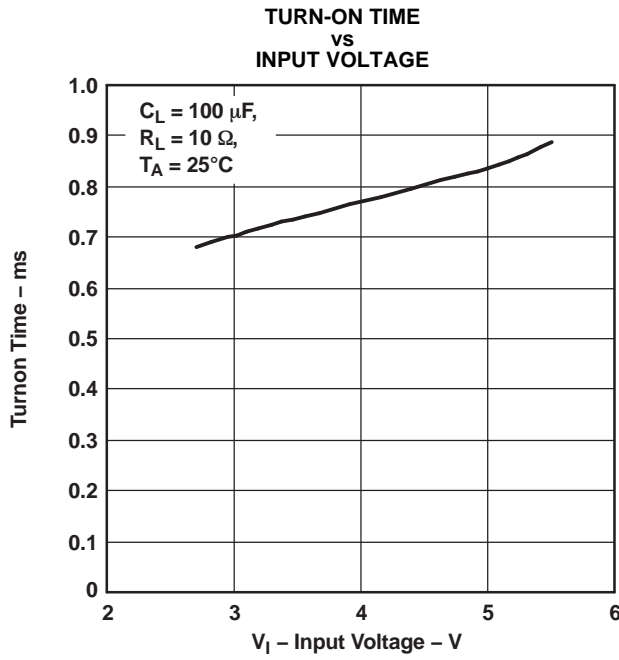

Figure 10.

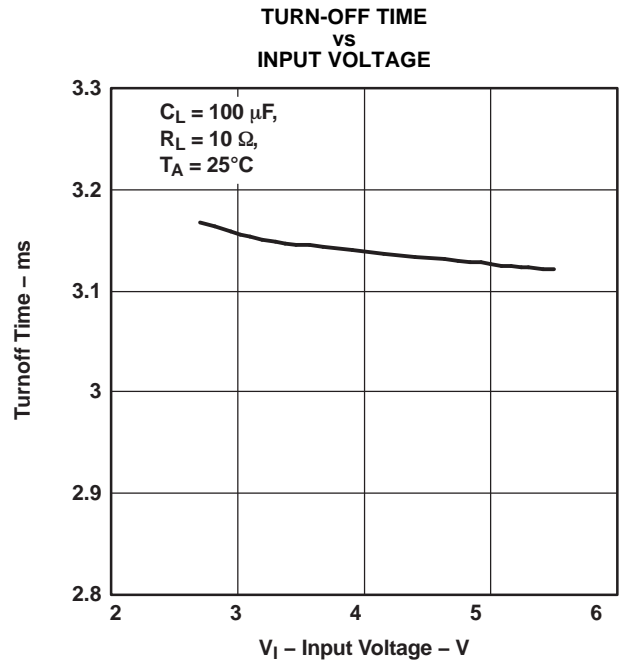

Figure 11.

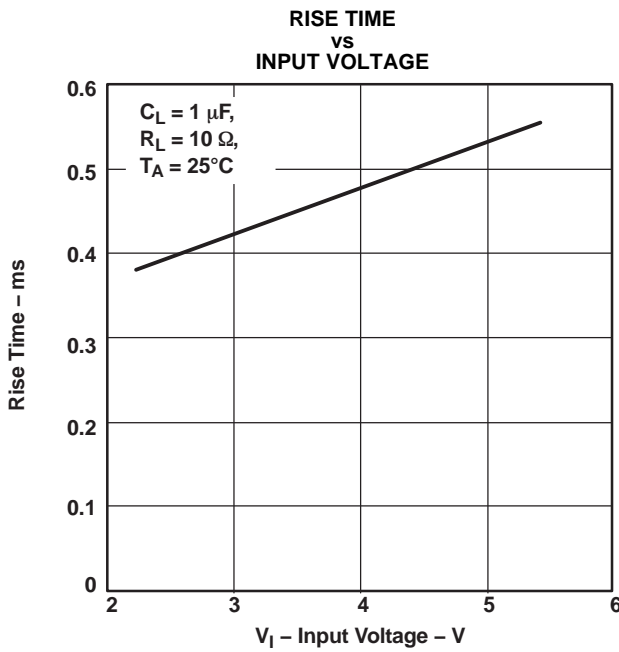

Figure 12.

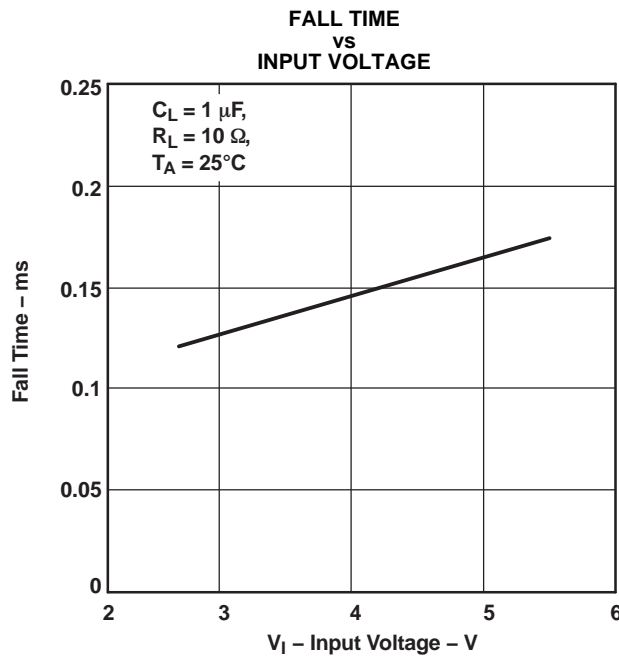

Figure 13.

TYPICAL CHARACTERISTICS (continued)

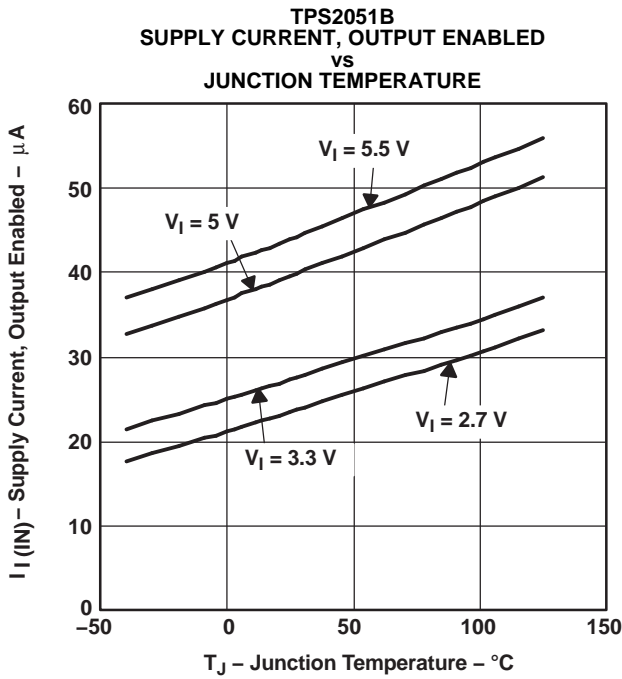

Figure 14.

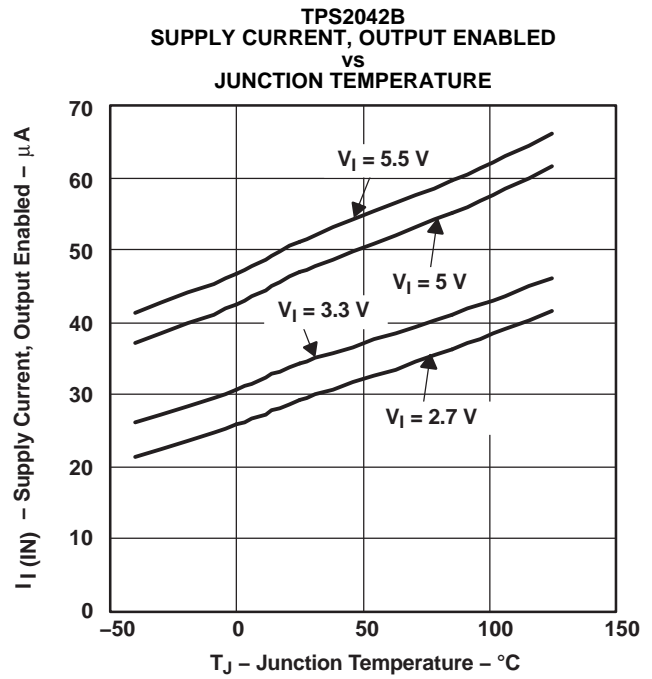

Figure 15.

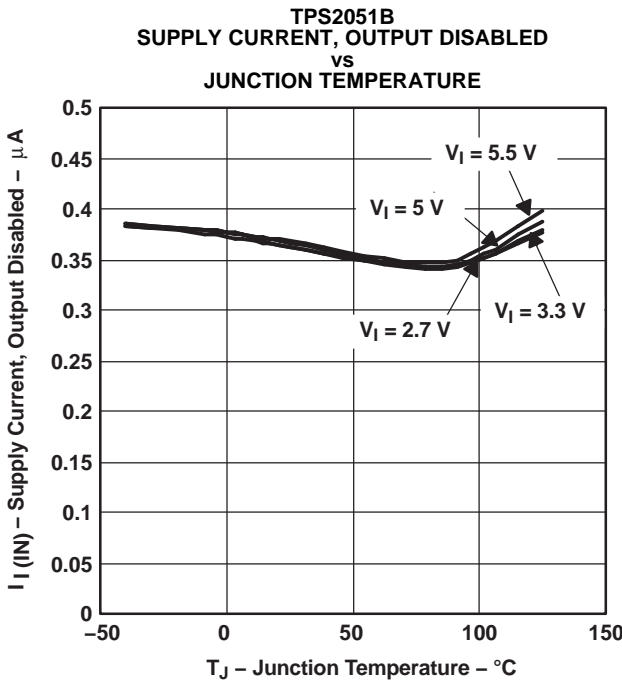

Figure 16.

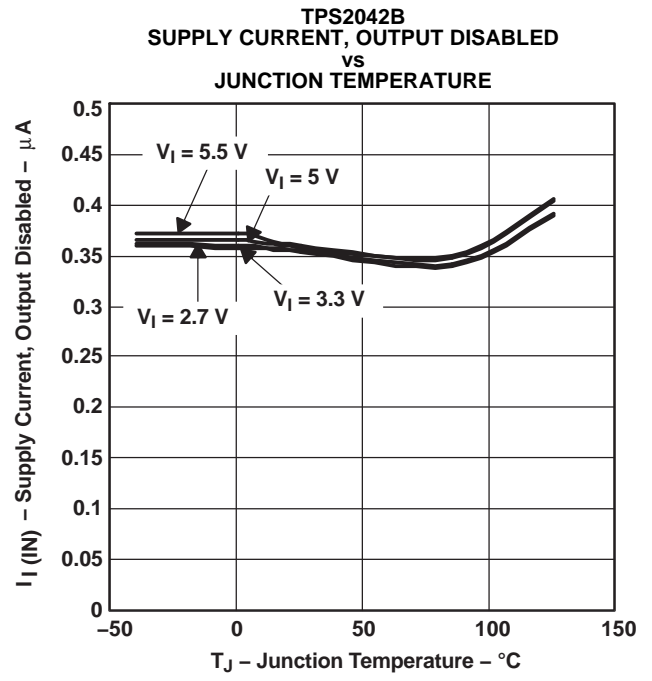

Figure 17.

TYPICAL CHARACTERISTICS (continued)

STATIC DRAIN-SOURCE ON-STATE RESISTANCE
vs
JUNCTION TEMPERATURE

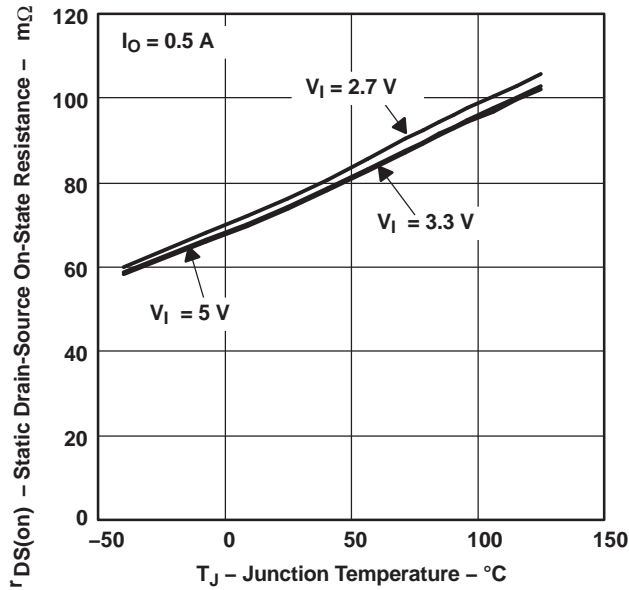

Figure 18.

SHORT-CIRCUIT OUTPUT CURRENT
vs
JUNCTION TEMPERATURE

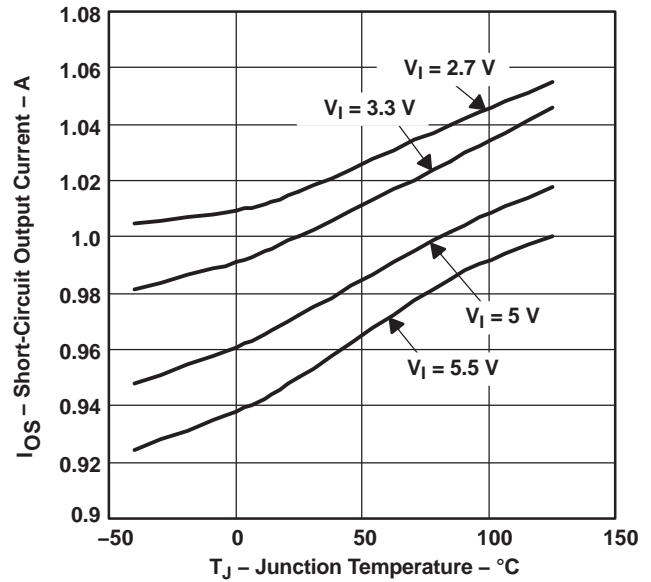

Figure 19.

THRESHOLD TRIP CURRENT
vs
INPUT VOLTAGE

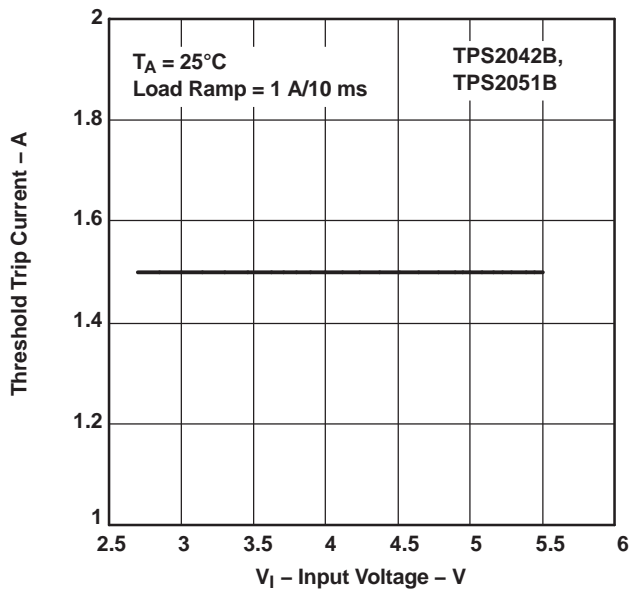

Figure 20.

UNDERVOLTAGE LOCKOUT
vs
JUNCTION TEMPERATURE

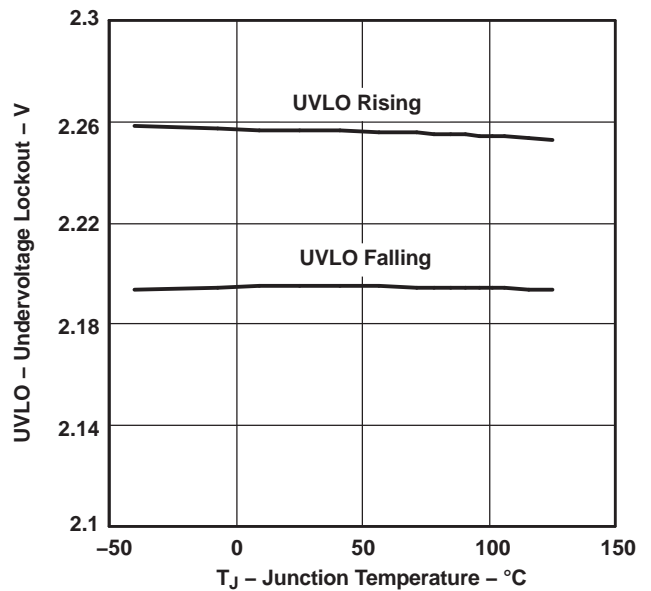
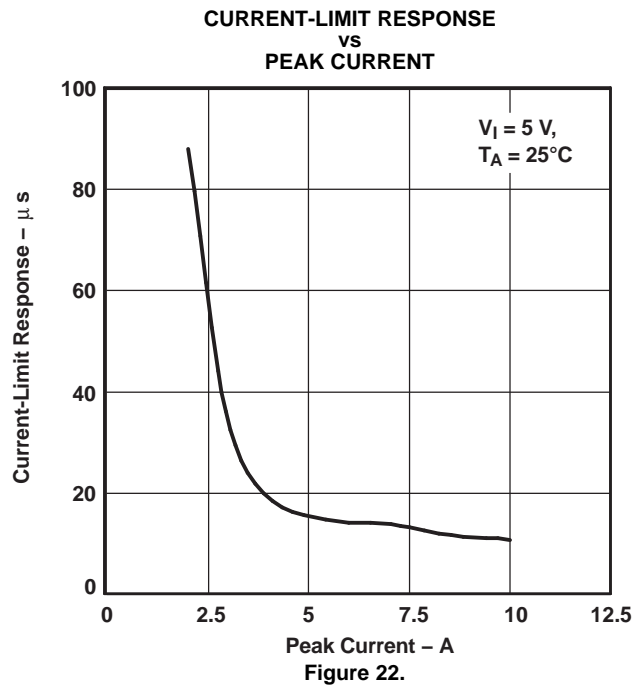

Figure 21.

TYPICAL CHARACTERISTICS (continued)



APPLICATION INFORMATION

Power-Supply Considerations

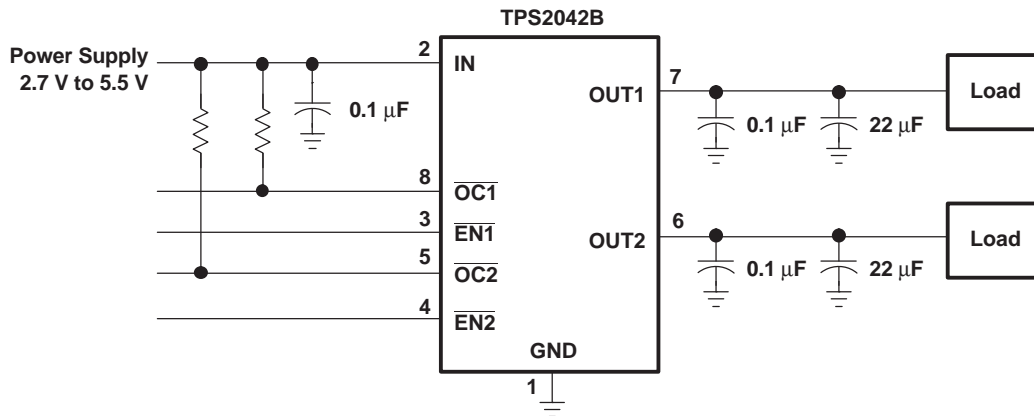

Figure 23. Typical Application (Example, TPS2042B)

A 0.01- μF to 0.1- μF ceramic bypass capacitor between IN and GND, close to the device, is recommended. Placing a high-value electrolytic capacitor on the output pin(s) is recommended when the output load is heavy. This precaution reduces power-supply transients that may cause ringing on the input. Additionally, bypassing the output with a 0.01- μF to 0.1- μF ceramic capacitor improves the immunity of the device to short-circuit transients.

Overcurrent

A sense FET is employed to check for overcurrent conditions. Unlike current-sense resistors, sense FETs do not increase the series resistance of the current path. When an overcurrent condition is detected, the device maintains a constant output current and reduces the output voltage accordingly. Complete shutdown occurs only if the fault is present long enough to activate thermal limiting.

Three possible overload conditions can occur. In the first condition, the output has been shorted before the device is enabled or before $V_{I(IN)}$ has been applied (see Figure 14 and Figure 15). The TPS2042B/TPS2051B senses the short and immediately switches into a constant-current output.

In the second condition, a short or an overload occurs while the device is enabled. At the instant the overload occurs, high currents may flow for a short period of time before the current-limit circuit can react. After the current-limit circuit has tripped (reached the overcurrent trip threshold), the device switches into constant-current mode.

In the third condition, the load has been gradually increased beyond the recommended operating current. The current is permitted to rise until the current-limit threshold is reached or until the thermal limit of the device is exceeded (see Figure 16 and Figure 17). The TPS2042B/TPS2051B is capable of delivering current up to the current-limit threshold without damaging the device. Once the threshold has been reached, the device switches into its constant-current mode.

$\overline{\text{OC}}$ Response

The $\overline{\text{OCx}}$ open-drain output is asserted (active low) when an overcurrent or overtemperature shutdown condition is encountered after a 10-ms deglitch timeout. The output remains asserted until the overcurrent or overtemperature condition is removed. Connecting a heavy capacitive load to an enabled device can cause a momentary overcurrent condition; however, no false reporting on $\overline{\text{OCx}}$ occurs due to the 10-ms deglitch circuit. The TPS2042B/TPS2051B is designed to eliminate false overcurrent reporting. The internal overcurrent deglitch eliminates the need for external components to remove unwanted pulses. $\overline{\text{OCx}}$ is not deglitched when the switch is turned off due to an overtemperature shutdown.

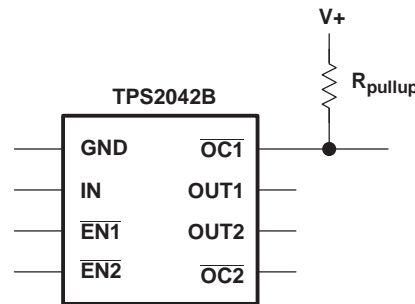

Figure 24. Typical Circuit for the \overline{OC} Pin (Example, TPS2042B)

Power Dissipation and Junction Temperature

The low on-resistance on the N-channel MOSFET allows the small surface-mount packages to pass large currents. The thermal resistances of these packages are high compared to those of power packages; it is good design practice to check power dissipation and junction temperature. Begin by determining the $r_{DS(on)}$ of the N-channel MOSFET relative to the input voltage and operating temperature. As an initial estimate, use the highest operating ambient temperature of interest and read $r_{DS(on)}$ from [Figure 18](#). Using this value, the power dissipation per switch can be calculated by:

$$P_D = r_{DS(on)} \times I^2$$

Multiply this number by the number of switches being used. This step renders the total power dissipation from the N-channel MOSFETs.

Finally, calculate the junction temperature:

$$T_J = P_D \times R_{\theta JA} + T_A$$

Where:

T_A = Ambient temperature ($^{\circ}\text{C}$)

$R_{\theta JA}$ = Thermal resistance

P_D = Total power dissipation based on number of switches being used.

Compare the calculated junction temperature with the initial estimate. If they do not agree within a few degrees, repeat the calculation, using the calculated value as the new estimate. Two or three iterations are generally sufficient to get a reasonable answer.

Thermal Protection

Thermal protection prevents damage to the IC when heavy-overload or short-circuit faults are present for extended periods of time. The TPS2042B/TPS2051B implements a thermal sensing to monitor the operating junction temperature of the power distribution switch. In an overcurrent or short-circuit condition, the junction temperature rises due to excessive power dissipation. Once the die temperature rises to approximately 140°C due to overcurrent conditions, the internal thermal sense circuitry turns the power switch off, thus preventing the power switch from damage. Hysteresis is built into the thermal sense circuit, and after the device has cooled approximately 10°C , the switch turns back on. The switch continues to cycle in this manner until the load fault or input power is removed. The \overline{OCx} open-drain output is asserted (active low) when an overtemperature shutdown or overcurrent occurs.

Undervoltage Lockout (UVLO)

The UVLO ensures that the power switch is in the off state at power up. Whenever the input voltage falls below approximately 2 V, the power switch is quickly turned off. This facilitates the design of hot-insertion systems where it is not possible to turn off the power switch before input power is removed. The UVLO also keeps the switch from being turned on until the power supply has reached at least 2 V, even if the switch is enabled. On reinsertion, the power switch is turned on, with a controlled rise time to reduce EMI and voltage overshoots.

Universal Serial Bus (USB) Applications

The universal serial bus (USB) interface is a 12-Mb/s, or 1.5-Mb/s, multiplexed serial bus designed for low-to-medium bandwidth PC peripherals (e.g., keyboards, printers, scanners, and mice). The four-wire USB interface is conceived for dynamic attach-detach (hot plug-unplug) of peripherals. Two lines are provided for differential data, and two lines are provided for 5-V power distribution.

USB data is a 3.3-V level signal, but power is distributed at 5 V to allow for voltage drops in cases where power is distributed through more than one hub across long cables. Each function must provide its own regulated 3.3 V from the 5-V input or its own internal power supply.

The USB specification defines the following five classes of devices, each differentiated by power-consumption requirements:

- Hosts/self-powered hubs (SPHs)
- Bus-powered hubs (BPHs)
- Low-power bus-powered functions
- High-power bus-powered functions
- Self-powered functions

Self-powered and bus-powered hubs distribute data and power to downstream functions. The TPS2042B/TPS2051B can provide power-distribution solutions to many of these classes of devices.

Hosts/Self-Powered Hubs and Bus-Powered Hubs

Hosts and self-powered hubs have a local power supply that powers the embedded functions and the downstream ports (see Figure 25). This power supply must provide from 5.25 V to 4.75 V to the board side of the downstream connection under full-load and no-load conditions. Hosts and SPHs are required to have current-limit protection and must report overcurrent conditions to the USB controller. Typical SPHs are desktop PCs, monitors, printers, and stand-alone hubs.

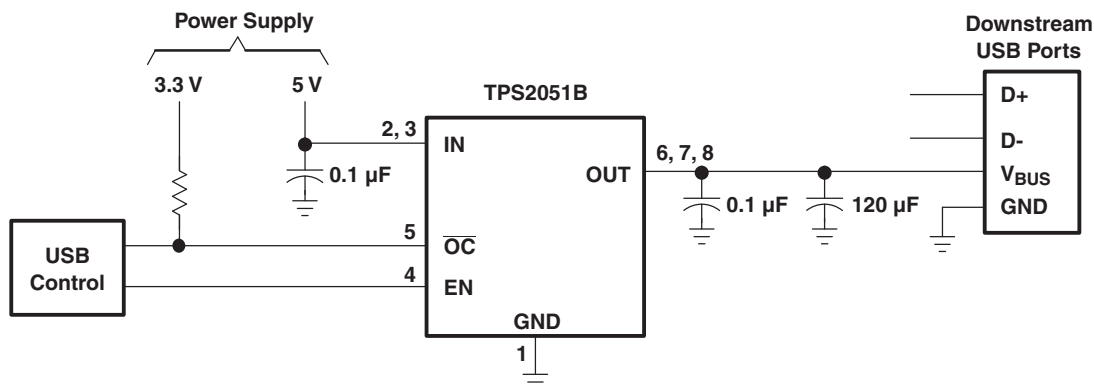

Figure 25. Typical One-Port USB Host/Self-Powered Hub

Bus-powered hubs obtain all power from upstream ports and often contain an embedded function. The hubs are required to power up with less than one unit load. The BPH usually has one embedded function, and power is always available to the controller of the hub. If the embedded function and hub require more than 100 mA on power up, the power to the embedded function may need to be kept off until enumeration is completed. This can be accomplished by removing power or by shutting off the clock to the embedded function. Power switching the embedded function is not necessary if the aggregate power draw for the function and controller is less than one unit load. The total current drawn by the bus-powered device is the sum of the current to the controller, the embedded function, and the downstream ports, and it is limited to 500 mA from an upstream port.

Low-Power and High-Power Bus-Powered Functions

Both low-power and high-power bus-powered functions obtain all power from upstream ports; low-power functions always draw less than 100 mA; high-power functions must draw less than 100 mA at power up and can draw up to 500 mA after enumeration. If the load of the function is more than the parallel combination of 44 Ω and 10 μF at power up, the device must implement inrush current limiting (see [Figure 26](#)).

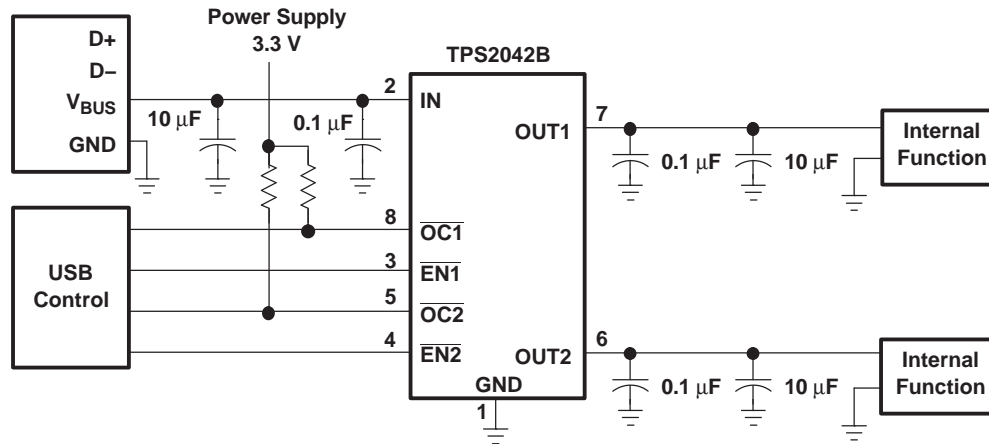

Figure 26. High-Power Bus-Powered Function (Example, TPS2042B)

USB Power-Distribution Requirements

USB can be implemented in several ways, and, regardless of the type of USB device being developed, several power-distribution features must be implemented.

- Hosts/self-powered hubs must:
 - Current-limit downstream ports
 - Report overcurrent conditions on USB V_{BUS}
- Bus-powered hubs must:
 - Enable/disable power to downstream ports
 - Power up at <100 mA
 - Limit inrush current (<44 Ω and 10 μF)
- Functions must:
 - Limit inrush currents
 - Power up at <100 mA

The feature set of the TPS2042B/TPS2051B allows them to meet each of these requirements. The integrated current-limiting and overcurrent reporting is required by hosts and self-powered hubs. The logic-level enable and controlled rise times meet the need of both input and output ports on bus-powered hubs, as well as the input ports for bus-powered functions (see [Figure 27](#) and [Figure 28](#)).

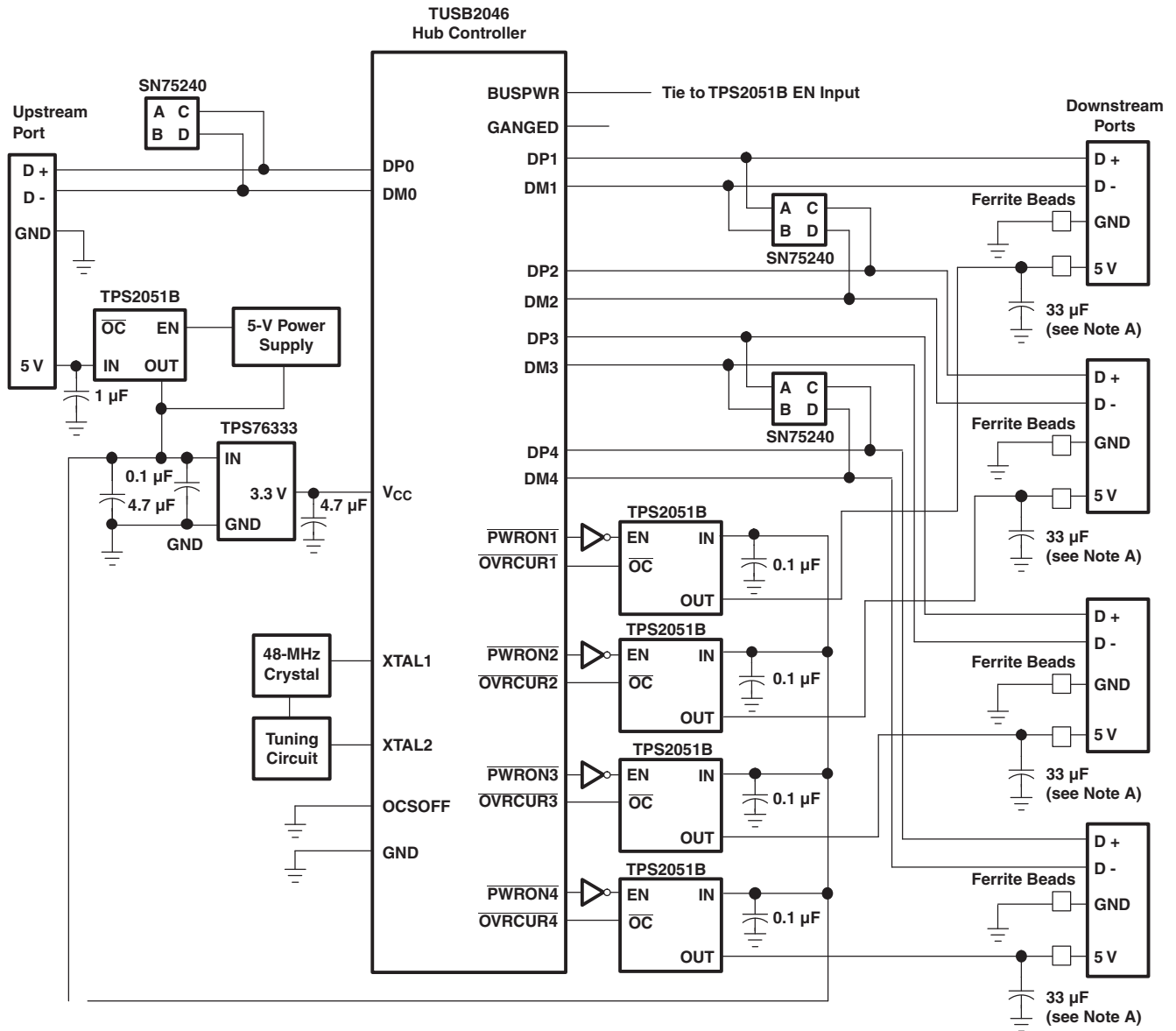

A. USB rev 1.1 requires 120 μF per hub.

Figure 27. Hybrid Self-Powered/Bus-Powered Hub Implementation (TPS2051B)

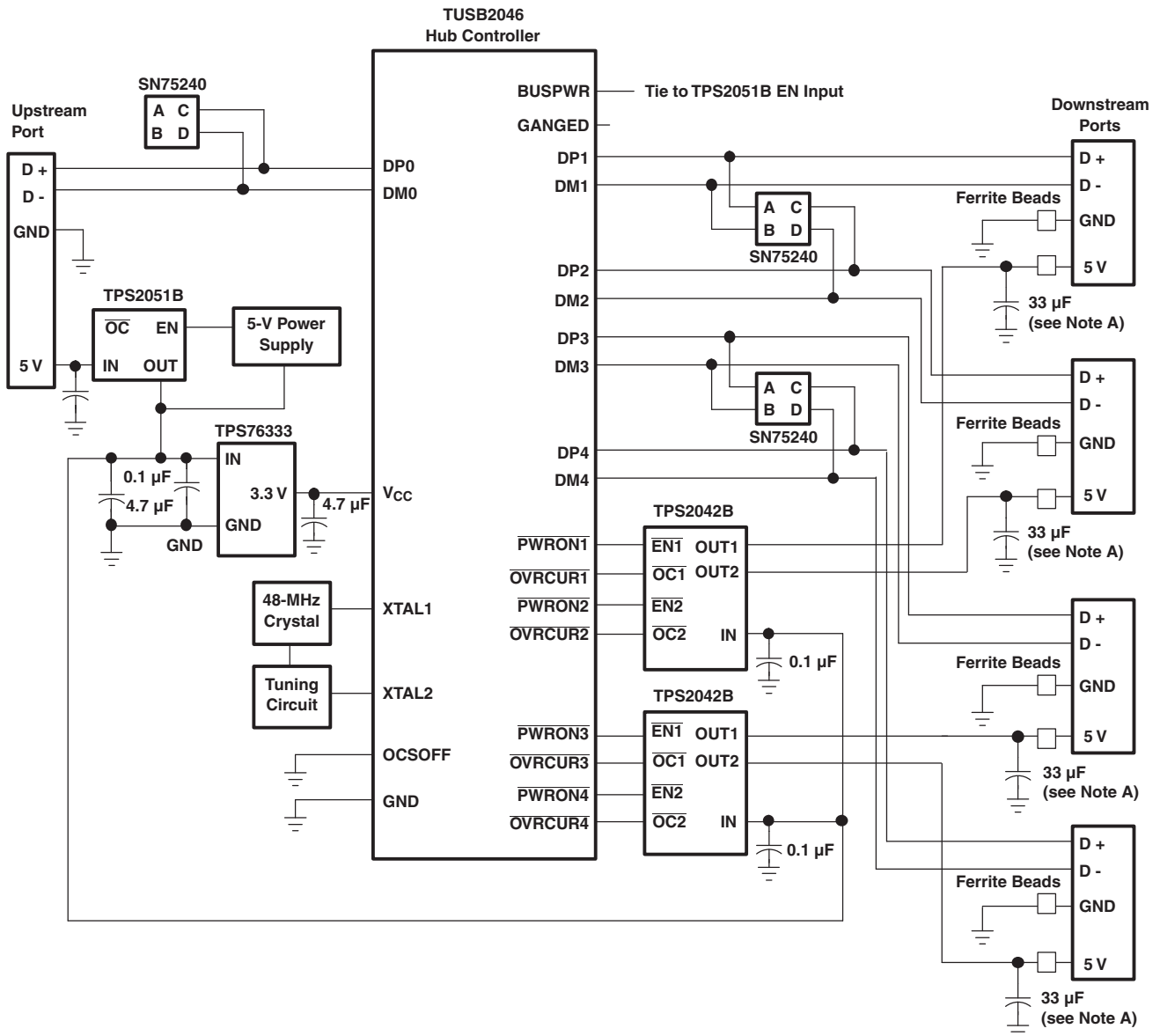

A. USB rev 1.1 requires 120 μF per hub.

Figure 28. Hybrid Self-Powered/Bus-Powered Hub Implementation (TPS2042B)

Generic Hot-Plug Applications

In many applications, it may be necessary to remove modules or PC boards while the main unit is still operating. These are considered hot-plug applications. Such implementations require the control of current surges seen by the main power supply and the card being inserted. The most effective way to control these surges is to limit and slowly ramp the current and voltage being applied to the card, similar to the way in which a power supply normally turns on. Due to the controlled rise times and fall times of the TPS2042B/TPS2051B, these devices can be used to provide a softer startup to devices being hot-plugged into a powered system. The UVLO feature of the TPS2042B/TPS2051B also ensures that the switch is off after the card has been removed, and that the switch is off during the next insertion. The UVLO feature ensures a softstart with a controlled rise time for every insertion of the card or module.

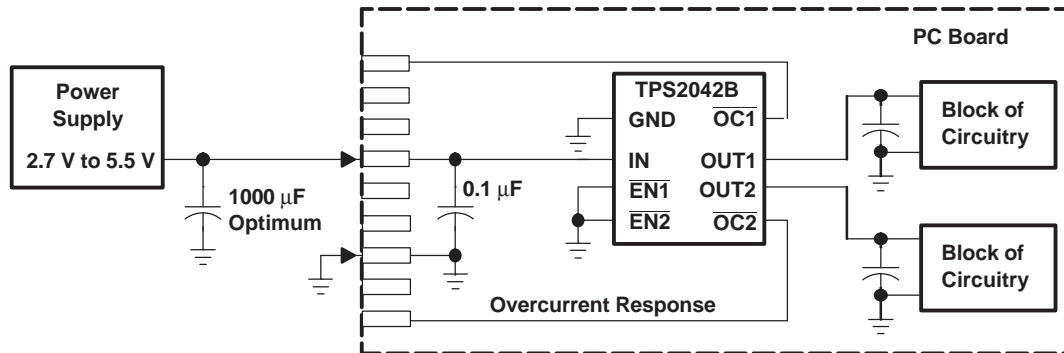

Figure 29. Typical Hot-Plug Implementation (Example, TPS2042B)

By placing the TPS2042B/TPS2051B between the V_{CC} input and the rest of the circuitry, the input power reaches these devices first after insertion. The typical rise time of the switch is approximately 1 ms, providing a slow voltage ramp at the output of the device. This implementation controls system surge currents and provides a hot-plugging mechanism for any device.

DETAILED DESCRIPTION

Power Switch

The power switch is an N-channel MOSFET with a low on-state resistance. Configured as a high-side switch, the power switch prevents current flow from OUT to IN and IN to OUT when disabled. The power switch supplies a minimum current of 500 mA.

Charge Pump

An internal charge pump supplies power to the driver circuit and provides the necessary voltage to pull the gate of the MOSFET above the source. The charge pump operates from input voltages as low as 2.7 V and requires little supply current.

Driver

The driver controls the gate voltage of the power switch. To limit large current surges and reduce the associated electromagnetic interference (EMI) produced, the driver incorporates circuitry that controls the rise times and fall times of the output voltage.

Enable (\overline{ENx})

The logic enable pin disables the power switch and the bias for the charge pump, driver, and other circuitry to reduce the supply current. The supply current is reduced to less than 1 μ A or 2 μ A when a logic high is present on \overline{EN} . A logic zero input on \overline{EN} restores bias to the drive and control circuits and turns the switch on. The enable input is compatible with both TTL and CMOS logic levels.

Enable (EN)

The logic enable disables the power switch and the bias for the charge pump, driver, and other circuitry to reduce the supply current. The supply current is reduced to less than 1 μA or 2 μA when a logic low is present on EN. A logic high input on EN restores bias to the drive and control circuits and turns the switch on. The enable input is compatible with both TTL and CMOS logic levels.

Overcurrent ($\overline{\text{OCx}}$)

The $\overline{\text{OCx}}$ open-drain output is asserted (active low) when an overcurrent or overtemperature condition is encountered. The output remains asserted until the overcurrent or overtemperature condition is removed. A 10-ms deglitch circuit prevents the $\overline{\text{OCx}}$ signal from oscillation or false triggering. If an overtemperature shutdown occurs, the $\overline{\text{OCx}}$ is asserted instantaneously.

Current Sense

A sense FET monitors the current supplied to the load. The sense FET measures current more efficiently than conventional resistance methods. When an overload or short circuit is encountered, the current-sense circuitry sends a control signal to the driver. The driver in turn reduces the gate voltage and drives the power FET into its saturation region, which switches the output into a constant-current mode and holds the current constant while varying the voltage on the load.

Thermal Sense

The TPS2042B/TPS2051B implements a thermal sensing to monitor the operating temperature of the power distribution switch. In an overcurrent or short-circuit condition, the junction temperature rises. When the die temperature rises to approximately 140°C due to overcurrent conditions, the internal thermal sense circuitry turns off the switch, thus preventing the device from damage. Hysteresis is built into the thermal sense, and after the device has cooled approximately 10 degrees, the switch turns back on. The switch continues to cycle off and on until the fault is removed. The open-drain false reporting output ($\overline{\text{OCx}}$) is asserted (active low) when an overtemperature shutdown or overcurrent occurs.

Undervoltage Lockout (UVLO)

A voltage sense circuit monitors the input voltage. When the input voltage is below approximately 2 V, a control signal turns off the power switch.

PACKAGING INFORMATION

Orderable Device	Status ⁽¹⁾	Package Type	Package Drawing	Pins	Package Qty	Eco Plan ⁽²⁾	Lead/Ball Finish	MSL Peak Temp ⁽³⁾
TPS2042BQDRQ1	ACTIVE	SOIC	D	8	2500	Green (RoHS & no Sb/Br)	CU NIPDAU	Level-1-260C-UNLIM
TPS2051BQDRQ1	ACTIVE	SOIC	D	8	2500	Green (RoHS & no Sb/Br)	CU NIPDAU	Level-1-260C-UNLIM

⁽¹⁾ The marketing status values are defined as follows:

ACTIVE: Product device recommended for new designs.

LIFEBUY: TI has announced that the device will be discontinued, and a lifetime-buy period is in effect.

NRND: Not recommended for new designs. Device is in production to support existing customers, but TI does not recommend using this part in a new design.

PREVIEW: Device has been announced but is not in production. Samples may or may not be available.

OBsolete: TI has discontinued the production of the device.

⁽²⁾ Eco Plan - The planned eco-friendly classification: Pb-Free (RoHS), Pb-Free (RoHS Exempt), or Green (RoHS & no Sb/Br) - please check <http://www.ti.com/productcontent> for the latest availability information and additional product content details.

TBD: The Pb-Free/Green conversion plan has not been defined.

Pb-Free (RoHS): TI's terms "Lead-Free" or "Pb-Free" mean semiconductor products that are compatible with the current RoHS requirements for all 6 substances, including the requirement that lead not exceed 0.1% by weight in homogeneous materials. Where designed to be soldered at high temperatures, TI Pb-Free products are suitable for use in specified lead-free processes.

Pb-Free (RoHS Exempt): This component has a RoHS exemption for either 1) lead-based flip-chip solder bumps used between the die and package, or 2) lead-based die adhesive used between the die and leadframe. The component is otherwise considered Pb-Free (RoHS compatible) as defined above.

Green (RoHS & no Sb/Br): TI defines "Green" to mean Pb-Free (RoHS compatible), and free of Bromine (Br) and Antimony (Sb) based flame retardants (Br or Sb do not exceed 0.1% by weight in homogeneous material)

⁽³⁾ MSL, Peak Temp. -- The Moisture Sensitivity Level rating according to the JEDEC industry standard classifications, and peak solder temperature.

Important Information and Disclaimer:The information provided on this page represents TI's knowledge and belief as of the date that it is provided. TI bases its knowledge and belief on information provided by third parties, and makes no representation or warranty as to the accuracy of such information. Efforts are underway to better integrate information from third parties. TI has taken and continues to take reasonable steps to provide representative and accurate information but may not have conducted destructive testing or chemical analysis on incoming materials and chemicals. TI and TI suppliers consider certain information to be proprietary, and thus CAS numbers and other limited information may not be available for release.

In no event shall TI's liability arising out of such information exceed the total purchase price of the TI part(s) at issue in this document sold by TI to Customer on an annual basis.

OTHER QUALIFIED VERSIONS OF TPS2042B-Q1, TPS2051B-Q1 :

- Catalog: [TPS2042B](#), [TPS2051B](#)

NOTE: Qualified Version Definitions:

- Catalog - TI's standard catalog product

D (R-PDSO-G8)

PLASTIC SMALL-OUTLINE PACKAGE

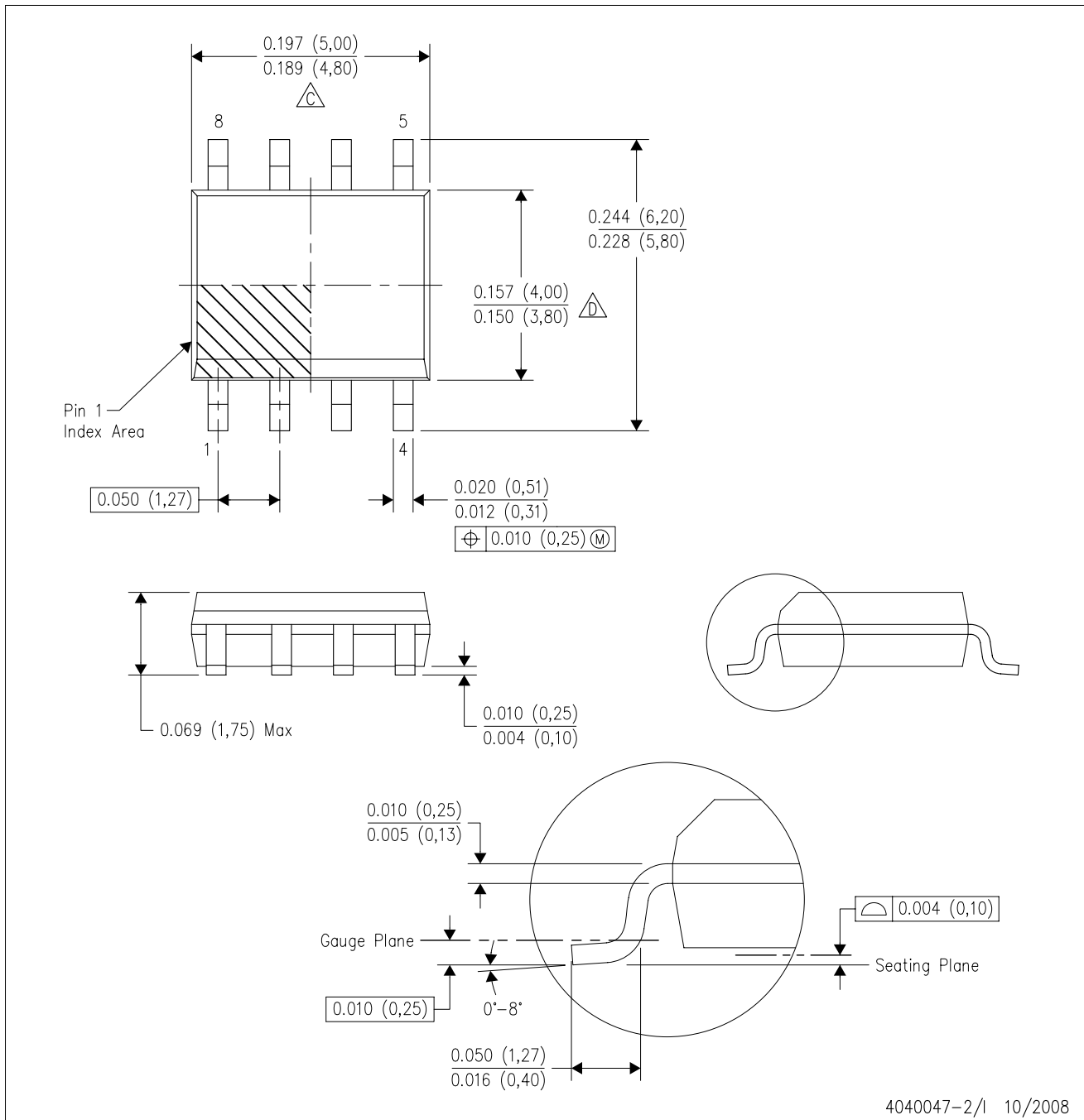

- NOTES:
- A. All linear dimensions are in inches (millimeters).
 - B. This drawing is subject to change without notice.
 - C. Body length does not include mold flash, protrusions, or gate burrs. Mold flash, protrusions, or gate burrs shall not exceed .006 (0,15) per end.
 - D. Body width does not include interlead flash. Interlead flash shall not exceed .017 (0,43) per side.
 - E. Reference JEDEC MS-012 variation AA.

IMPORTANT NOTICE

Texas Instruments Incorporated and its subsidiaries (TI) reserve the right to make corrections, modifications, enhancements, improvements, and other changes to its products and services at any time and to discontinue any product or service without notice. Customers should obtain the latest relevant information before placing orders and should verify that such information is current and complete. All products are sold subject to TI's terms and conditions of sale supplied at the time of order acknowledgment.

TI warrants performance of its hardware products to the specifications applicable at the time of sale in accordance with TI's standard warranty. Testing and other quality control techniques are used to the extent TI deems necessary to support this warranty. Except where mandated by government requirements, testing of all parameters of each product is not necessarily performed.

TI assumes no liability for applications assistance or customer product design. Customers are responsible for their products and applications using TI components. To minimize the risks associated with customer products and applications, customers should provide adequate design and operating safeguards.

TI does not warrant or represent that any license, either express or implied, is granted under any TI patent right, copyright, mask work right, or other TI intellectual property right relating to any combination, machine, or process in which TI products or services are used. Information published by TI regarding third-party products or services does not constitute a license from TI to use such products or services or a warranty or endorsement thereof. Use of such information may require a license from a third party under the patents or other intellectual property of the third party, or a license from TI under the patents or other intellectual property of TI.

Reproduction of TI information in TI data books or data sheets is permissible only if reproduction is without alteration and is accompanied by all associated warranties, conditions, limitations, and notices. Reproduction of this information with alteration is an unfair and deceptive business practice. TI is not responsible or liable for such altered documentation. Information of third parties may be subject to additional restrictions.

Resale of TI products or services with statements different from or beyond the parameters stated by TI for that product or service voids all express and any implied warranties for the associated TI product or service and is an unfair and deceptive business practice. TI is not responsible or liable for any such statements.

TI products are not authorized for use in safety-critical applications (such as life support) where a failure of the TI product would reasonably be expected to cause severe personal injury or death, unless officers of the parties have executed an agreement specifically governing such use. Buyers represent that they have all necessary expertise in the safety and regulatory ramifications of their applications, and acknowledge and agree that they are solely responsible for all legal, regulatory and safety-related requirements concerning their products and any use of TI products in such safety-critical applications, notwithstanding any applications-related information or support that may be provided by TI. Further, Buyers must fully indemnify TI and its representatives against any damages arising out of the use of TI products in such safety-critical applications.

TI products are neither designed nor intended for use in military/aerospace applications or environments unless the TI products are specifically designated by TI as military-grade or "enhanced plastic." Only products designated by TI as military-grade meet military specifications. Buyers acknowledge and agree that any such use of TI products which TI has not designated as military-grade is solely at the Buyer's risk, and that they are solely responsible for compliance with all legal and regulatory requirements in connection with such use.

TI products are neither designed nor intended for use in automotive applications or environments unless the specific TI products are designated by TI as compliant with ISO/TS 16949 requirements. Buyers acknowledge and agree that, if they use any non-designated products in automotive applications, TI will not be responsible for any failure to meet such requirements.

Following are URLs where you can obtain information on other Texas Instruments products and application solutions:

Products

Amplifiers	amplifier.ti.com
Data Converters	dataconverter.ti.com
DSP	dsp.ti.com
Clocks and Timers	www.ti.com/clocks
Interface	interface.ti.com
Logic	logic.ti.com
Power Mgmt	power.ti.com
Microcontrollers	microcontroller.ti.com
RFID	www.ti-rfid.com
RF/IF and ZigBee® Solutions	www.ti.com/lprf

Applications

Audio	www.ti.com/audio
Automotive	www.ti.com/automotive
Broadband	www.ti.com/broadband
Digital Control	www.ti.com/digitalcontrol
Medical	www.ti.com/medical
Military	www.ti.com/military
Optical Networking	www.ti.com/opticalnetwork
Security	www.ti.com/security
Telephony	www.ti.com/telephony
Video & Imaging	www.ti.com/video
Wireless	www.ti.com/wireless

Mailing Address: Texas Instruments, Post Office Box 655303, Dallas, Texas 75265
Copyright © 2008, Texas Instruments Incorporated